

# OPERATING INSTRUCTIONS FOR TYPE 377-B LOW-FREQUENCY OSCILLATOR\*

**B**EFORE discussing the characteristics of the TYPE 377-B Low-Frequency Oscillator, it may be of interest to outline briefly the theory of its operation so that the necessity for certain adjustments may be better appreciated.

Consider the amplifier circuit shown in Figure 1. In accordance with the usual tube theory, a small sinusoidal voltage  $e_g$  applied to the grid will be amplified in the customary way, giving rise to a slightly distorted plate-current wave. Most of the higher harmonics are filtered out in the tuned circuit so that the voltage  $e_s$  across the transformer secondary will be essentially sinusoidal. If the resistance  $R$  is properly chosen, this secondary voltage can be made exactly equal to the applied grid voltage. When this has been done, we may connect the circuit as shown in Figure 2, and oscillations will be sustained. The departure of the grid voltage from a sine wave depends upon the magnitude of the swing and operating point and also upon the selectivity of the tuned circuit. Just as in the usual amplifier theory, the least distortion will be present when the grid-voltage-plate-

current characteristic of the tube is essentially straight.

It has been found that the grid current in an oscillator tube provides a remarkably simple and accurate means for estimating the amplitude of oscillation. For a given grid current, we can say that the grid swing has a definite value, regardless of the characteristic of the coil and the frequency chosen. Hence, if  $R$  is adjusted to give a predetermined grid current, the grid will be operating at a given swing, a consideration of prime importance when the signal is to supply an amplifier tube.

For those who may be interested, a brief sketch of the details is given in Appendix A. The important point to be noticed is the close analogy between an oscillator of this type and a tuned amplifier. Further application of this analogy can be made to account exactly for the waveform obtained and for the variation of frequency with operating point, but this is too involved to be of interest.

The circuit finally adopted for the TYPE 377-B Low-Frequency Oscillator is shown schematically in Figure 6 where it will be noticed that it follows the outline given above. An adjustable 100,000-ohm rheostat  $R$  is used as a feed-back resistance and it should be adjusted to give a grid

\* This material has been adapted from an article, "A Low-Frequency Oscillator," by L. B. Arguimbau, *The General Radio Experimenter*, IV, October, 1929.

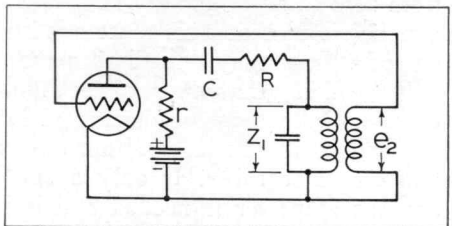
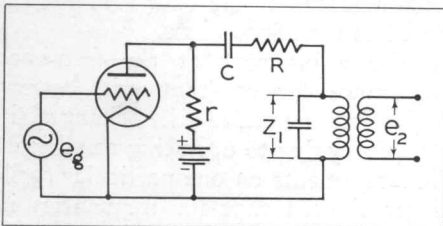

FIGURE 1. LEFT: Vacuum-tube amplifier with input voltage  $e_g$  and output voltage  $e_s$   
FIGURE 2. RIGHT: The amplifier becomes an oscillator when its output impedance is supplied from its own circuit

current of 30 micro-amperes (as indicated on a 0-200 micro-ampere meter mounted on the panel). The 50,000-ohm plate-supply resistance  $r$  provides a good coupling device and at the same time limits the oscillator plate current to about 2 milliamperes. In Figure 6 a tuned-plate oscillator is shown. In practice it was found desirable to use a Hartley circuit for the lower end of the range, using the tuned-plate circuit at higher frequencies.

It will be noticed that the output power is taken off across a wire-wound potentiometer in the plate circuit of the last tube. This was done for two reasons: to prevent interaction with the oscillator tube and to prevent the waveform from varying excessively with the output setting. It should be noticed that this arrangement makes the effective output impedance of the oscillator depend upon the potentiometer setting. In a few isolated cases (such as measurements on harmonic production in non-linear circuits) this is undesirable, but for all ordinary purposes it causes no difficulty. Measurements on harmonic production and allied phenomena require special precautions, and no ordinary coupling device should be used without a careful consideration of its effect on the circuit being studied. In all measurements on linear circuits where the effect of harmonic flow is of no interest, the impedance of the generator tube need not be considered; by proper connections, any source impedance from zero to an arbitrarily large value can be simulated. This matter is discussed at length in Appendix B, page 6.

Recognizing that the needs of different users will vary somewhat, provision has been made for using either one or two amplifier tubes. If only a small amount of power is needed and it is desired to reduce battery drain to a minimum, only one tube need be used; the total plate current will then be

about 10 milliamperes. Without any change in the circuit, a second tube may be added in parallel; in this case, the plate current will then be about 16 milliamperes. Typical output characteristics for these two cases are shown in Figure 5. If a greater amount of power is necessary, the use of a suitable external power amplifier is recommended. In any event, the feed-back resistance should be adjusted to give a grid-current reading of not more than 30 micro-amperes. Grid currents greater than that value indicate distortion in the waveform of the output voltage.

A series of measurements has been made with a harmonic analyzer to determine the dependence of waveform on operating conditions. These measurements show that the voltage wave given by the oscillator tube itself contains no harmonic having an amplitude larger than 0.5 per cent. of the fundamental. On the other hand, the amplifier has been designed to deliver the maximum amount of power consistent with the usual requirements on waveform. Harmonics introduced by the amplifier may amount to 3 per cent. of the fundamental. If much better waveform is required, it is necessary to reduce the signal level at which the last stage is operating. This may be accomplished by substituting a 1.0 megohm resistance for the 0.5 megohm unit in the place marked A in Figure 6. This change reduces the harmonics to 1.0 per cent. of the fundamental, if the load resistance is not less than 8000 ohms.

The adjustment of the feed-back resistance for constant grid current helps to minimize the changes in frequency due to operating conditions. Measurements on one particular oscillator showed that for frequencies in the neighborhood of 40 cycles, changes in plate battery amounting to 25 per cent. made a change in frequency of

less than 0.1 per cent. when the feedback was readjusted to give 30 micro-amperes. If no adjustment was made, the departure was less than 0.3 per cent. If the grid current was allowed to depart by 10 micro-amperes from the rated value, the frequency drift was not more than 0.3 per cent. Changing the oscillator tube gave rise to similar differences. At 25 cycles the changes were about twice as large as those mentioned (i.e., a maximum of about one-tenth of a cycle).

These figures refer to frequency changes covered by tubes and operating points. Ageing effects may be larger but they should never exceed 3 per cent.

The frequency of the oscillator is continuously adjustable by means of the seven controls placed at the bottom of the panel. There are three coils so tapped that they can be thrown into circuit in six ways by means of the three key switches. Below them are three rotary switches controlling a decade-condenser system having a total capacitance of 1.11 microfarads and to the left is a variable air condenser with a maximum capacitance of 0.0011 microfarads for making fine adjustments.

The figures 0.001, 0.01, and 0.1

above the decade-condenser controls are the capacitances in microfarads per division corresponding to the engraved scale. This and the fact that the capacitance of the variable air condenser is proportional to angle (number of scale divisions) gives a means of making approximate interpolations between frequencies not given on the calibration chart. The frequency is very nearly inversely proportional to the square root of the capacitance.

The frequency range of the instrument as normally supplied is from 25 to 70,000 cycles per second, but it can if necessary be extended slightly in either direction by a change in construction. Prices and other details will be furnished on application to the Service Department of the General Radio Company.

The oscillator is calibrated with an accuracy of one per cent. and the calibration data is supplied in duplicate. One copy is mounted on the inside cover of the instrument; the other is mounted in a metal chart holder. On the chart the column headed "Coil Switch" shows the position of key switches. Coil switches, positions for which are not specified, are to be left in the "Off" or neutral position. The remaining two columns specify the

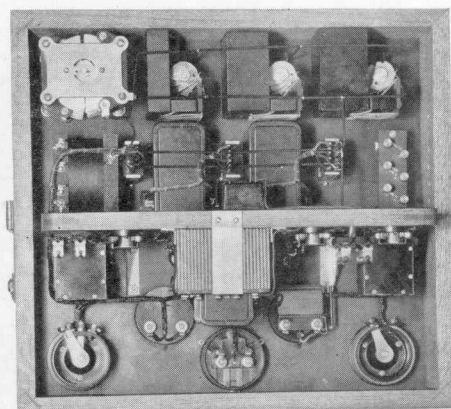
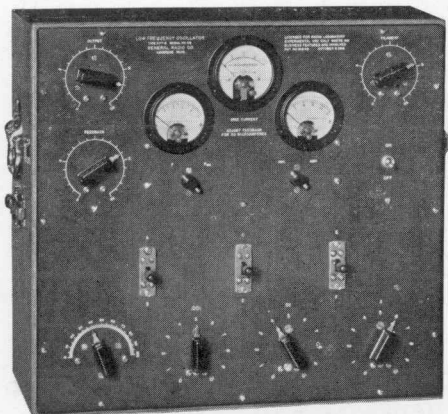

FIGURE 3. Front and rear panel views of TYPE 377-B Low-Frequency Oscillator. The rear view shows the method of mounting the grid-biasing battery

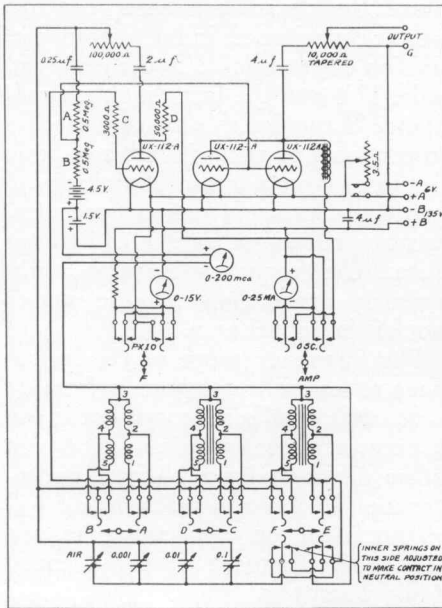

FIGURE 4. Wiring diagram for TYPE 377-B Low-Frequency Oscillator

setting for the decade-condenser system and for the variable air condenser.

TUBE AND BATTERY DATA

Use 112-A type tubes; plate-battery voltage, 135 volts; filament voltage, 5 volts; grid-battery voltage, 1.5 volts for oscillator, 6 volts for amplifiers.

For the grid-biasing battery, use a Burgess Type 5540 or its equivalent. This battery should be replaced at least every six months. Failure to do so will result in bad waveform and some shift in frequency.

APPENDIX A

Consider the amplifier circuit shown in Figure 1. Assume a sinusoidal voltage  $e_g$  impressed on the grid. When this swing is very small, we may treat the circuit in accordance with the usual tube theory, considering the tube as a sinusoidal generator  $\mu e_g$  in series with a resistance  $r_p$ , the internal plate impedance of the tube. Neglecting the effect of the shunt resistance  $r$  and

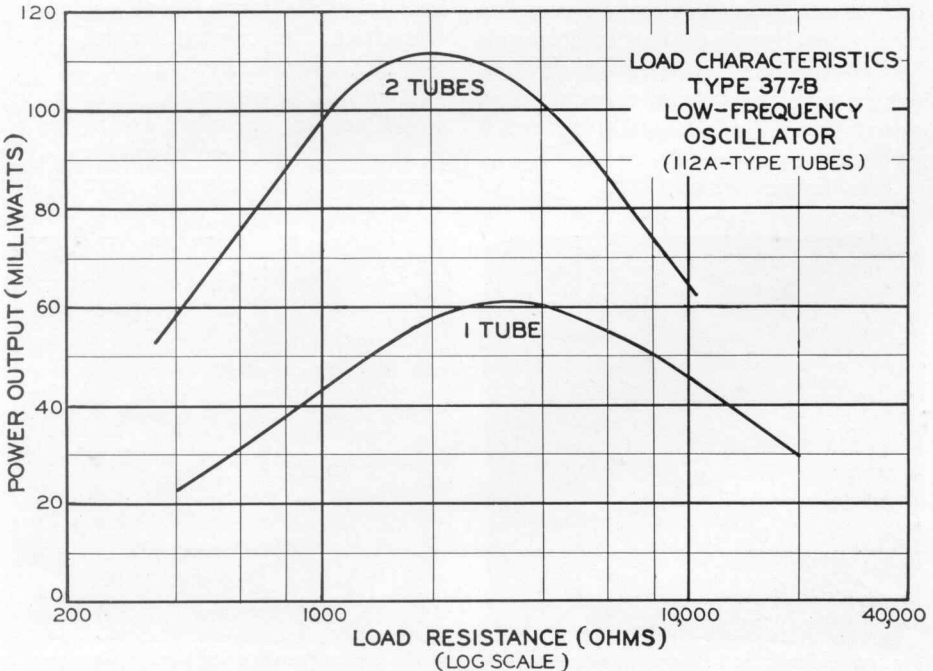

FIGURE 5. Power output of the oscillator as a function of load resistance

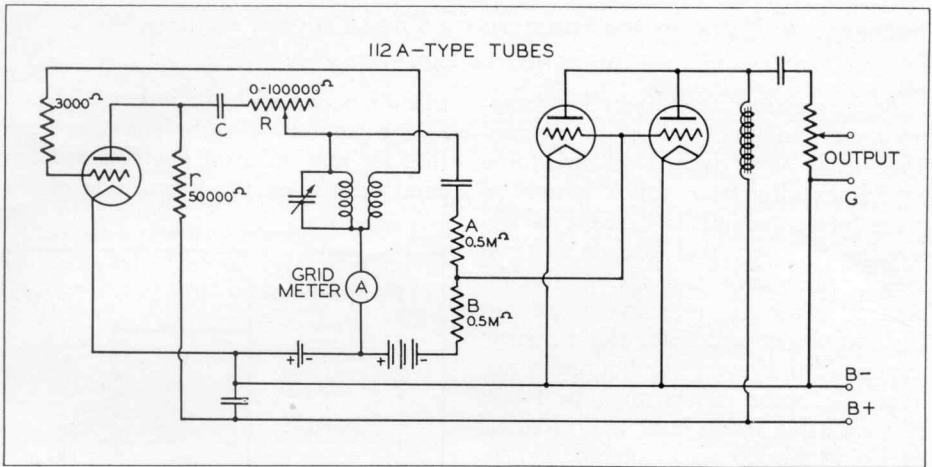

FIGURE 6. Functional schematic diagram for the TYPE 377-B Low-Frequency Oscillator

the condenser  $C^*$  we may write for the magnitude of the voltage across the secondary,

$$e_2 = \frac{n_2}{n_1} \cdot \frac{Z_1}{r_p + R + Z_1} \cdot \mu e_g \quad (1)$$

$Z_1$  is the impedance of the parallel circuit, and  $\frac{n_2}{n_1}$  is the turns ratio of the transformer. Even though some distortion is produced by variations in plate resistance introducing harmonics in the plate current, the voltage across the tuned circuit  $Z_1$  will be very nearly sinusoidal. (Actually, the harmonics at this point can be kept below 0.5 per cent.) It is to be noted that for a given tuned circuit and tubes (i.e., given  $Z_1$

\* By the use of Thévenin's Theorem we may eliminate the effect of the parallel resistance  $r$  and the condenser  $C$  by making the substitutions,

$$\mu' = \left( \frac{1}{1 + \frac{r_p}{r}} \right) \mu \quad \text{and} \quad r_p' = \left( \frac{1}{1 + \frac{r_p}{r}} \right) r_p - j \frac{1}{\omega C}$$

using these new quantities in place of  $\mu$  and  $r_p$ . It will be noticed that this has little effect when

$$r_p \ll r \quad \text{and} \quad \frac{1}{\omega C} \ll r.$$

and  $r_p$ ), the secondary voltage can be regarded as a function of the coupling resistance  $R$ . In particular, if  $Z_1$  is sufficiently high we can choose  $R$  in such a manner that the secondary voltage  $e_2$  is equal to the applied grid voltage  $e_g$ . When this has been done we may rewrite (1):

$$r_p + R = \left( \mu \frac{n_2}{n_1} - 1 \right) Z_1.$$

Actually, of course, this is not the whole story. In practice the amplitude will adjust itself until the dynamic plate impedance satisfies the above equation. By properly choosing  $R$ , however, we can select any such equilibrium position, thereby fixing the amplitude. The flow of harmonics out-of-phase with the fundamental will introduce a reactive component in the plate impedance and cause the frequency to assume such a value as to give an equal and opposite phase shift in the tuned circuit. This phase shift will be obtained in the case of a sharply resonant circuit by a much smaller percentage change in frequency than is the case in a broadly tuned circuit.

## APPENDIX B: METHODS FOR SIMULATING A POWER SOURCE HAVING ANY VALUE OF INTERNAL IMPEDANCE\*

An interesting communication measurement problem makes its appearance when it is desired to determine experimentally how much power a given power source is capable of delivering to a specified load or sink. So long as the source itself is available for test, it is merely necessary to set up the equipment and make the measurements. If, however, the source is not available, some means must be found of simulating it. At least two methods for doing the job are available, and we propose to describe them. Both are perfectly general: the "source" may be a vacuum-tube oscillator or a microphone or an incoming transmission line; the "load" may be a loud-speaker or an attenuation network or an outgoing transmission line. There are only two restrictions: the "source" must supply a sinusoidal voltage, and the impedance of the "load" must not depend upon the current in it.

A generalized statement about networks called Thévenin's Theorem gives directly one of the methods for setting up a simulating source. We shall defer stating it until later because it will simplify matters to set up a specific hypothetical problem, follow through its solution, and with that as a basis, state the general law. Our discussion must be understood to be an attempt to show that Thévenin's Theorem is plausible without trying to prove it.

Consider, for example, the load circuit shown in Figure 7. Its impedance at a given frequency is  $Z_R$ ; the voltage drop, current, and absorbed power which correspond to  $Z_R$  are, respectively,  $E_R$ ,  $I_R$ , and  $W_R$ . Inasmuch

as  $Z_R$  is assumed to be independent of  $I_R$ , we can make the obvious statement that for any value of  $Z_R$ ,  $W_R$  will depend only upon the magnitude of  $E_R$

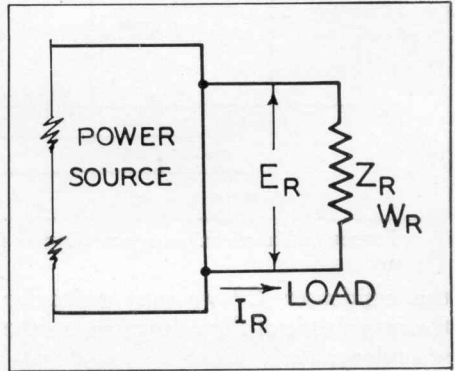

FIGURE 7

(or of  $I_R$ , since  $E$  and  $I$  are linked by Ohm's Law).

Now suppose that we want to determine experimentally how much power the load will absorb at different frequencies from a given power source which is not available for the tests. What must we do in order to set up a simulating source? We have just seen that the only way a source can affect  $W_R$  is to change  $E_R$ . Therefore, all we need do to simulate the given source is to make sure that, no matter what value  $Z_R$  may assume (as a result of changing the test frequency, for example),  $E_R$  for the simulating source is the same as  $E_R$  for the source itself. In other words, no power measurements on the load could tell us which of two sources was supplying power if the terminal voltages ( $E_R$ ) of each were the same.

Let us also assume that the source to be simulated is an alternator which delivers a constant voltage at its output terminals no matter what load is

\*This material has been adapted from an article, "Notes on Power Measurement in Communication Circuits," by John D. Crawford, *The General Radio Experimenter*, IV, November, 1929.

thrown upon it.\* Because of a high-impedance line between the alternator and its load terminals, the voltage at the load terminals depends upon the size of the load. This condition is represented in Figure 8, where  $E$  is the volt-

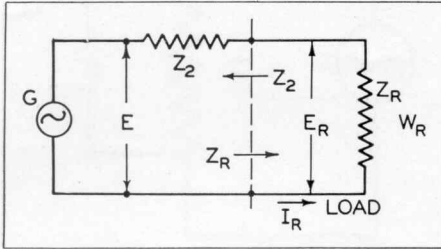

FIGURE 8

age of the alternator,  $G$ , and  $Z_2$  is the impedance of the line.  $E_R$  is therefore always less than  $E$  by  $E_2$ , the voltage drop in  $Z_2$ . In other words,  $W_R$  depends upon  $Z_2$ .

From what has gone before,  $Z_2$  may be considered a part of a new load,  $Z'_R$ , having an impedance of  $Z_2 + Z_R$ . The power delivered to this new load will, as before, be fixed if the voltage drop across it is fixed. The generator,  $G$ , delivers constant voltage under all conditions of load, a fact which enables us to build a simulating source. Since the load cannot distinguish between one generator and another if the impressed voltages are the same, we can take any generator, maintain its terminal voltage equal to  $E$  by manual adjustment, and the power delivered to  $Z'_R$  will be the same for both the actual and the simulating sources. Furthermore, the voltage drop in  $Z_2$  will be the same under both conditions, and the power delivered to  $Z_R$  will be the same as though it were connected to the original source. Therefore, we have shown that any generator connected in series with an impedance equal to  $Z_2$  will simulate this particular

\*An oscillator which could do exactly that would be a curiosity, having, as we shall point out later, a negligible "internal impedance."

source, if the voltage at the generator terminals is maintained constant and equal to  $E$ .

From the foregoing discussion we may conclude that the presence of  $Z_2$ , the internal impedance for the given power source, is the reason why changes in the magnitude of  $Z_R$  affect the terminal voltage  $E_R$ . If  $Z_2$  is equal to zero,  $E_R$  would be constant and equal to  $E$ , the open-circuit voltage of the source; but if  $Z_2$  is not zero, then every decrease in the magnitude of  $Z_R$  causes  $E_R$  to be less than  $E$  by the voltage drop in  $Z_2 = I_R Z_2$ . Furthermore, any generator or any source behaves as though it had no internal impedance if its terminal voltage is maintained constant.

Suppose that  $G$  were not a constant-voltage generator, or, in other words, suppose that its terminal voltage  $E$  depended upon the amount of current taken by the load. This would, of course, indicate that somewhere ahead of its output terminals there existed an appreciable impedance. To simulate this new source we would proceed exactly as before: maintain the simulating-generator voltage constant and equal to the open-circuit voltage of the source and connect in series with it an impedance equal to  $Z_G + Z_2$ , the sum of the internal impedance of  $G$  and the impedance of the intervening connecting wires.

It is now time to discard all of our labored attempts at a simple and orderly development to state the general law about which we spoke at the beginning of this section. It is a corollary of Thévenin's Theorem, a theorem that is capable of a formal proof with which we shall not concern ourselves here. Thévenin's Theorem permits us to state that any power source can be simulated (Figure 9) by a generator with a terminal voltage  $E$  connected in series with an impedance  $Z$ ;  $E$  being equal to the no-load or open-circuit

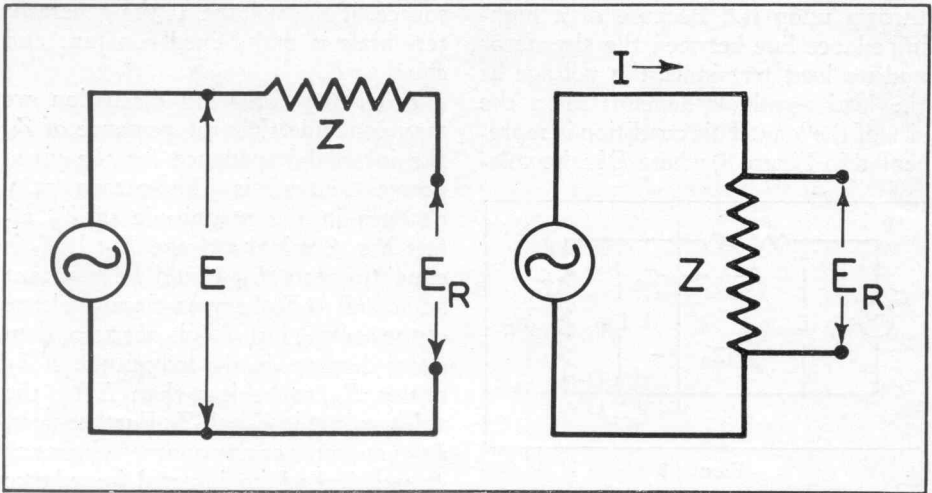

FIGURE 9. Two methods for simulating a power source when its open-circuit voltage  $E=IZ$  and its internal impedance  $Z$  are known. LEFT: Constant-voltage method. RIGHT: Constant-current method

voltage of the source and  $Z$  being equal to the impedance of the source *as seen from its output terminals*. This can be verified experimentally for a simple source like the one we have been discussing by connecting an oscillator to a load of adjustable but known impedance and observing its terminal voltage as a function of delivered power or of load impedance or of current. Errors due to bad waveform and overloading in the oscillator must not be allowed to enter.

The diagram at the right in Figure 9 shows the second simulating method and although it does not follow directly from Thévenin's Theorem, it can be shown to be entirely consistent with it. In the second method, constant current is maintained through the parallel circuit formed by  $Z$ , the impedance of the simulating source, and the load impedance; the constant current being such as to make the no-load voltage drop across the simulating impedance

equivalent to the no-load voltage of the power source. If we can show that for any value of  $Z_R$  the voltage  $E_R$  is the same for both the constant-current and the constant-voltage methods, the two are equivalent.

Imagine that both circuits are terminated in a load  $Z_R$ :

(a) for constant-voltage method,

$$E_R = I_R Z_R = \left( \frac{E}{Z + Z_R} \right) Z_R = \frac{E Z_R}{Z + Z_R};$$

(b) for constant-current method,

$$E_R = I \left( \frac{Z_R Z}{Z + Z_R} \right) = \frac{E}{Z} \left( \frac{Z_R Z}{Z + Z_R} \right) = \frac{E Z_R}{Z + Z_R}.$$

If the voltage of the source is non-sinusoidal or the impedance of the load is non-linear (i.e., a function of current), special care must be used in applying these simulating methods. The same care must be exercised when studying transient effects, since our discussion has been tacitly limited to the steady-state condition.